

DUNHAM-BUSH®

DUNHAM STRIP RADIANT HEATING



Products that perform... By people who care



Contents

	Page
Identification	2
Introduction	2
Authority	2
Description	2
Composition	2
Range	2
Accessories	4
Performance	5
Heat outputs	5
Correction factors	5
Mounting heights	5
Capacities	5
Masses	5
Application	6
General	6
Selection	6
Heating media	6
Selection guidelines	6
Dimensions	7-8
Engineering specification	9
Construction	9
Handling	9
Storage	9
Preparation	9
Installation	9
Pipework connections	9
Prices & Conditions of Sale	10
Prices	10
Conditions of sale	10
Supply	11
Availability	11
Packaging	11
Ordering	11

Identification

Introduction

Dunham Strip is the solution for industrial radiant heating from central plant. It is supplied in simple, modular strips ready for installation and connection to pumped hot water or steam systems, providing maintenance-free heating.

Unlike conventional warm air heating, radiant heating provides a unique heating effect by infra-red radiation, creating ideal comfort conditions at a lower design ambient air temperature. Radiant heating will heat building occupants directly, without the need to warm the air surrounding them.

Authority

It is accepted practice and policy at Dunham-Bush to maintain exceptional standards in engineering and quality. To this end, Dunham-Bush operates a quality system and is registered as a firm of assessed capability to BS EN ISO 9001 : 2000

Description

Composition

Dunham Strip comprises aluminium sheet panels with steel pipe clamped to the upper surface. The pipes are located in a single groove in the panel to maximise the physical interface between pipe and panel, ensuring efficient heat transfer to the radiating surface. The panels have a durable coating of epoxy polyester powder, and are fitted with insulation to minimise heat losses above the panel.

A range of accessories are supplied loose, giving flexibility in system design and configuration. Accessories include hanging brackets, cover plates and end closers.

Range

Dunham Strip is manufactured in one or two pipe strips, available in four nominal lengths. A one pipe and two pipe strip can be mounted in parallel to make a three pipe strip, and two pipe strips can be mounted in parallel to make four pipe strips. Mounting brackets are available for suspending one, two, three and four pipe configurations.

Nominal lengths are 1.5m, 3.0m, 4.5m, and 6.0m, and can be connected to form longer strips. The steel pipe is BS EN 10 255 (BS 1387) DN32 (1¼") medium weight ('blue band'), with the option of heavy weight ('red band') pipe. Pipes are supplied with plain ends as standard, there are also options for screwed ends to BS EN 10 226 (BS 21); fitted weldneck flanged ends to BS EN 1092 (BS 4504); grooved to accept 'Victaulic' type couplings; and box headers with flange connections are also available.

Dunham Strip is also available in special finishes, to any colour and gloss level from the RAL and BS 4800 range of colours.

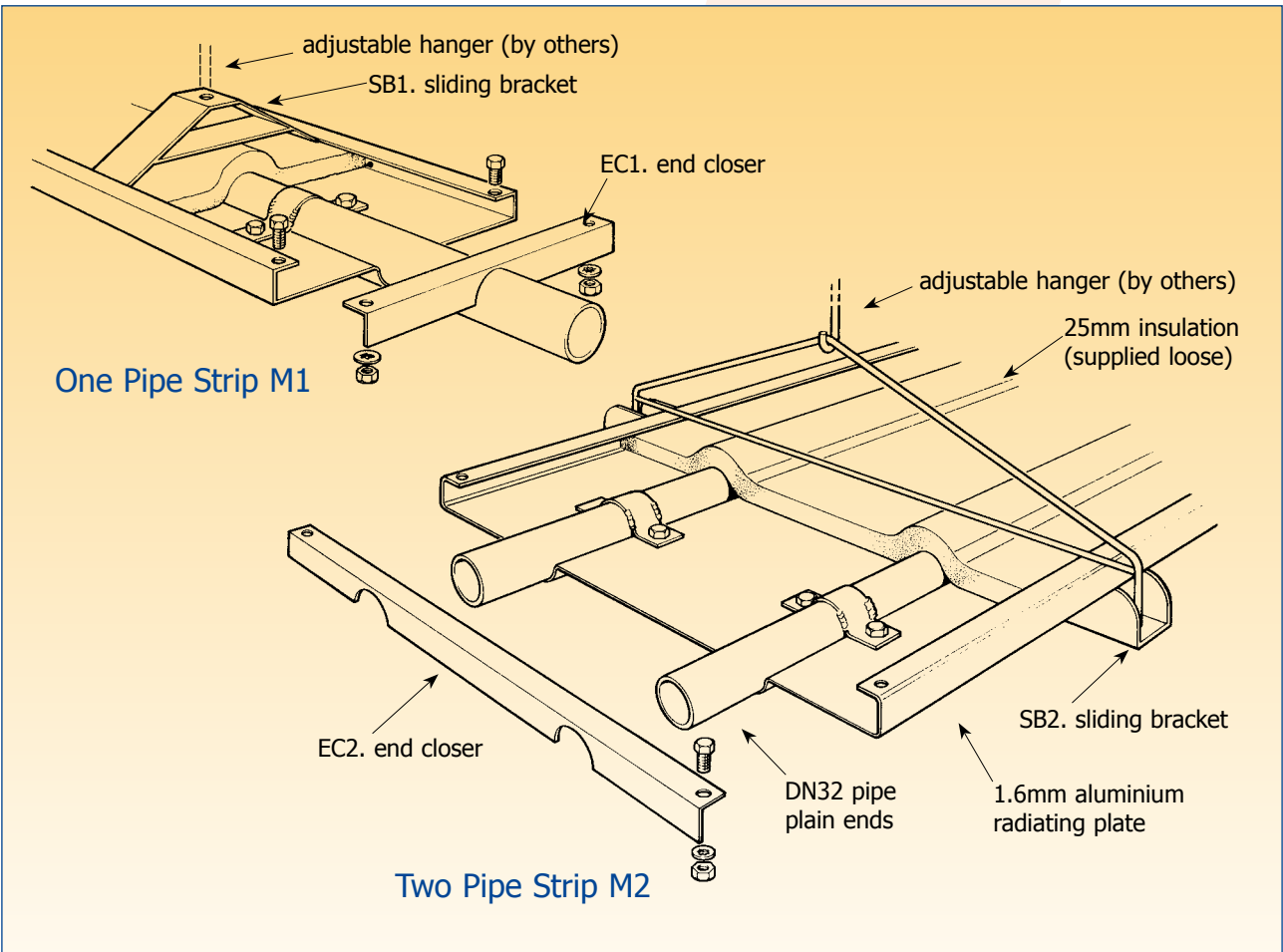

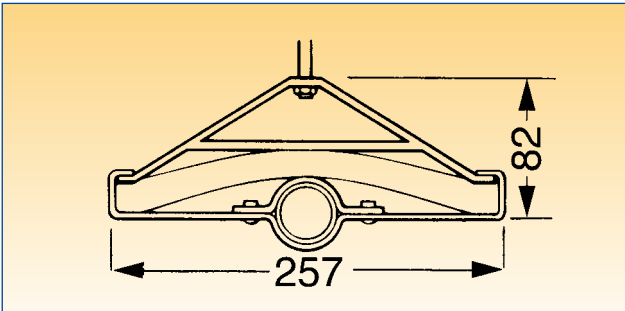

M1 Dunham Strip

suspended with SB1 sliding bracket suitable for 10mm drop rod

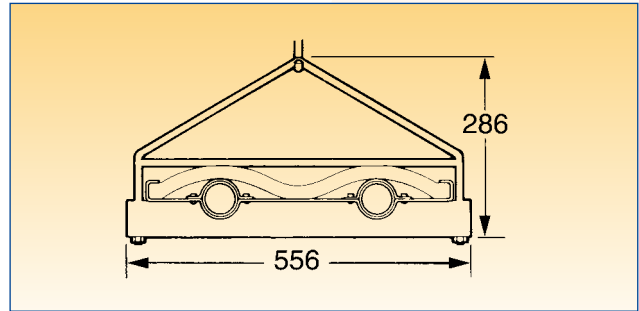

M2 Dunham Strip

suspended with SB2 sliding bracket suitable for 10mm drop rod

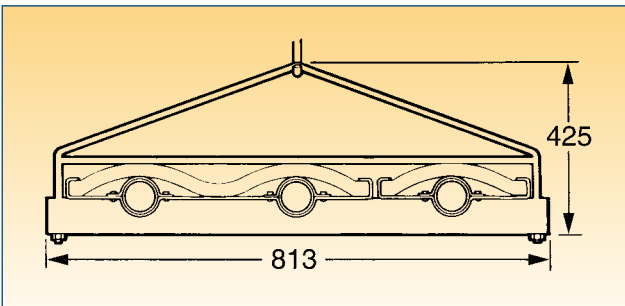

M3 Dunham Strip

comprising M1 and M2 strip in parallel suspended with SB3 sliding bracket suitable for 10mm drop rod

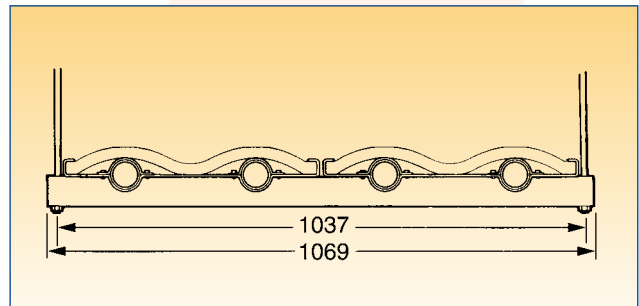

M4 Dunham Strip

comprising 2 no. M2 strips in parallel suspended with SB4 sliding bracket suitable for 2 no. 10mm drop rods

Accessories

Sliding bracket kits are supplied loose for hanging the strip. There are four bracket types :-

SB1 for M1 - 1 pipe SB2 for M2 - 2 pipe SB3 for M3 - 3 pipe SB4 for M4 - 4 pipe

End cover kits can be provided to finish the end of a strip; there are two types :-

EC1 for M1 - 1 pipe EC2 for M2 - 2 pipe

Cover plate kits can be provided to cover connections between adjoining strips, presenting a continuous run of strip.

There are two types :

CP1 for 1 pipe Dunham Strip

CP2 for 2 pipe Dunham Strip

Note; CP1 & CP2 are not suitable for flanged connections.

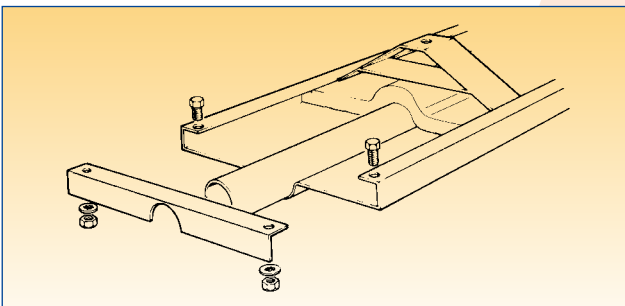

EC1 - End closer for M1 Dunham Strip

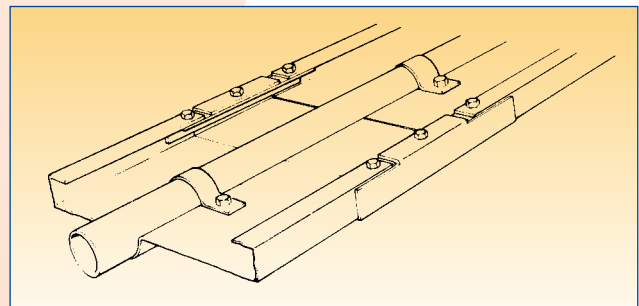

CP1 - Cover plate for M1 Dunham Strip



Performance

Heat outputs

Δt (°C)	Total output (w/m)			
	M1 - 1 pipe	M2 - 2 pipe	M3 - 3 pipe	M4 - 4 pipe
50	128	256	384	512
60	155	311	466	622
70	183	366	549	733
80	211	422	633	844
90	239	478	718	957
100	268	535	803	1070
110	296	592	888	1184
120	325	650	974	1299
130	354	707	1061	1415
140	383	765	1148	1531
150	412	824	1235	1647
160	441	882	1323	1764
170	470	941	1411	1881
180	500	1000	1500	1999

Table 1: Heat outputs to BS EN 442 Part 2 for horizontally mounted Dunham Strip

- Notes
1. For hot water heating, Δt = mean water temperature minus air dry-bulb temperature.
 2. For steam heating, the temperature difference Δt can be taken as saturated steam temperature corresponding to the normal operating pressure.
 3. Outputs are valid for air and mean radiant temperatures in the range 10°C to 25°C.
 4. Downward radiation is approximately 60% of total heat output.
 5. For hot water heating, outputs are based on hot water with an in-pipe velocity of 0.3m/s. For economy and to ensure air clearance, a velocity of 0.5m/s is recommended.
 6. Maximum recommended steam pressure is 10bar gauge.

Correction factors

Water velocity (m/s)	0.10	0.15	0.20	0.25	0.30
Correction factor	0.91	0.95	0.97	0.99	1.00

Table 2: Approximate correction factors for total output for various hot water velocities.

Correction factors can be applied to outputs in table 1.

Installation angle	30°	45°	60°	90°
Correction factor	1.05	1.06	1.08	1.08

Table 3: Approximate correction factors for total output for installation angles to the horizontal

Correction factors can be applied to outputs in table 1; the increase in total output is normally convective

Capacities

Medium pipe	Water content (l/m)	Heavy pipe	Water content (l/m)
M1	1.02	M1	0.93
M2	2.04	M2	1.86
M3	3.06	M3	2.79
M4	4.08	M4	3.72

Table 4: Water content per linear metre of Dunham Strip for one, two, three and four pipe strip

Masses

Medium pipe	Mass (kg/m)	Heavy pipe	Mass (kg/m)
M1	5.3	M1	6.1
M2	10.3	M2	11.8
M3	15.6	M3	17.8
M4	20.6	M4	23.6

Table 5: Approximate shipping masses per linear metre of Dunham Strip without accessories



Application

General

Dunham Strip radiant heating is the ideal choice of radiant heating for large, open industrial buildings, where cost, low maintenance and simplicity are primary considerations. It is especially suited to hazardous areas where a "spark-free" environment is essential. The slimline profile of Dunham Strip is complemented by space-saving accessories, which minimise impact on the building structure and other building services. Typical applications are railway locomotive workshops, aircraft hangars, bus garages, automotive workshops, spray booths, magazines and medium-light manufacturing buildings.

Selection

The total heat load of the building must be calculated in accordance with recognised practice. Heat loads should be calculated using the internal design air temperature (dry bulb). However, the internal design air temperature can be reduced since mean radiant temperatures are elevated by radiant heating.

The total heat load should be divided by the total heat output per metre, as given in table 1, with the appropriate correction factors applied from tables 2 and 3. This will then give the required overall length of M1, M2, M3 or M4 radiant panels.

Heating Media

Medium and high temperature hot water as well as steam are the best heating media for Dunham Strip. Low temperature hot water is also suitable, but this will result in a higher quantity of Dunham Strip being required for a given output.

Selection Guidelines

The following guidelines are to assist the designer in deciding the best layout for Dunham Strip

1. Layout - Runs of Dunham Strip should be spaced out as evenly as possible to give uniform coverage over the heated area.
2. Run spacing - The distance between adjacent runs should not exceed the mounting height - this will minimise cold spots forming.
3. Maximum mounting height - In tall, narrow buildings, wall absorption will reduce the effectiveness of radiant heating. Thus, the mounting height should be limited to 2/3 of the building width e.g. for a building 18m wide, the mounting height should not exceed 12m.
4. Minimum mounting height - If mounting heights are too low, radiant intensity will increase leading to discomfort for building occupants.
5. Pipe circuitry - When using hot water, check that the water velocity is in the range 0.3-0.5m/s to give the rated outputs. For lower water velocities, apply the correction factors in table 2. When using steam, runs should not exceed 45m in length and should be graded at approximately 1:200 down to a suitable steam trap, strainer and valve set.
6. Expansion - When using hot water, expansion loops/joints may not be needed if end connections and return loops are given sufficient flexibility. But for steam, expansion loops/joints are recommended. Multi-tube Dunham Strip should have tubes connected in parallel with the water flow in the same direction, to minimise bowing caused by differential expansion.
N.B. Sliding brackets are designed to give variable installation position only, not to provide expansion movement - thus, hanging rods should be long enough to allow for expansion movement.



Dimensions (standard)

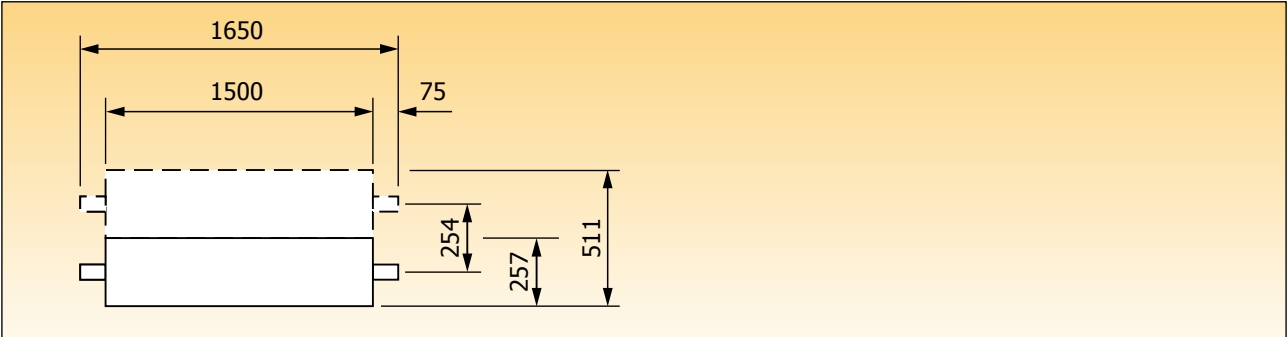

M1 and M2 strip - nominal length 1.5m

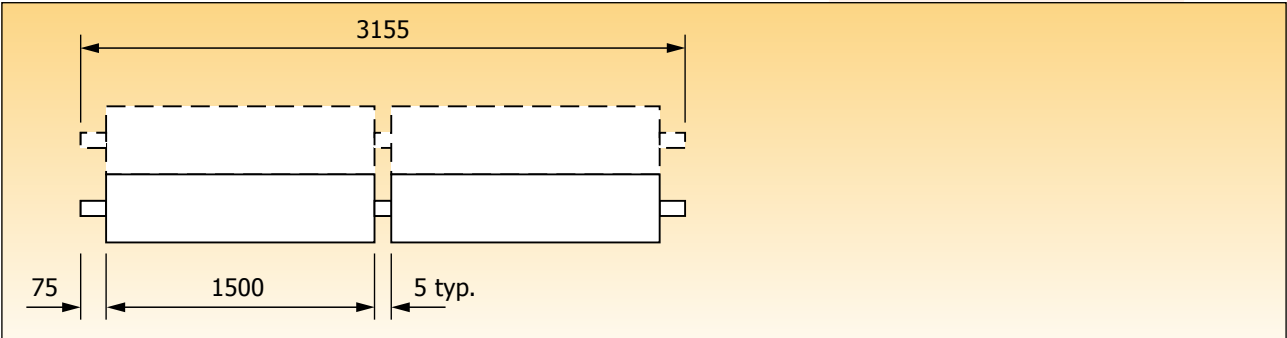

M1 and M2 strip - nominal length 3.0m

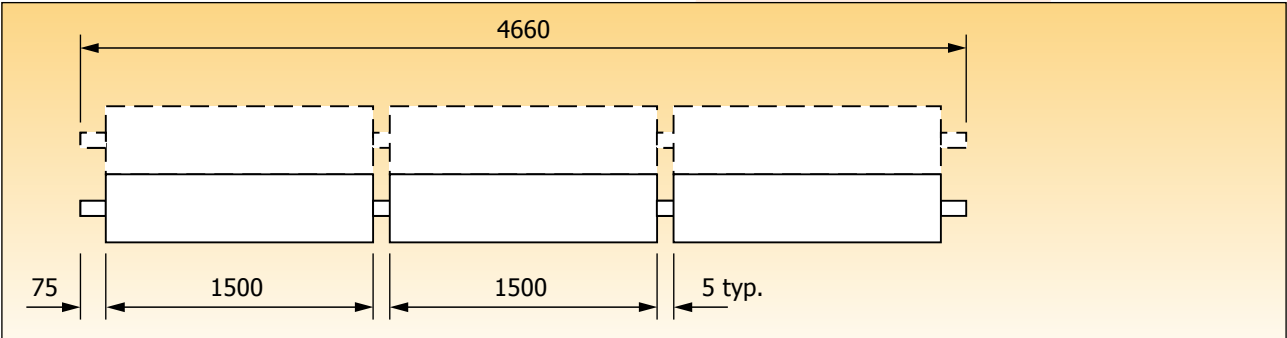

M1 and M2 strip - nominal length 4.5m

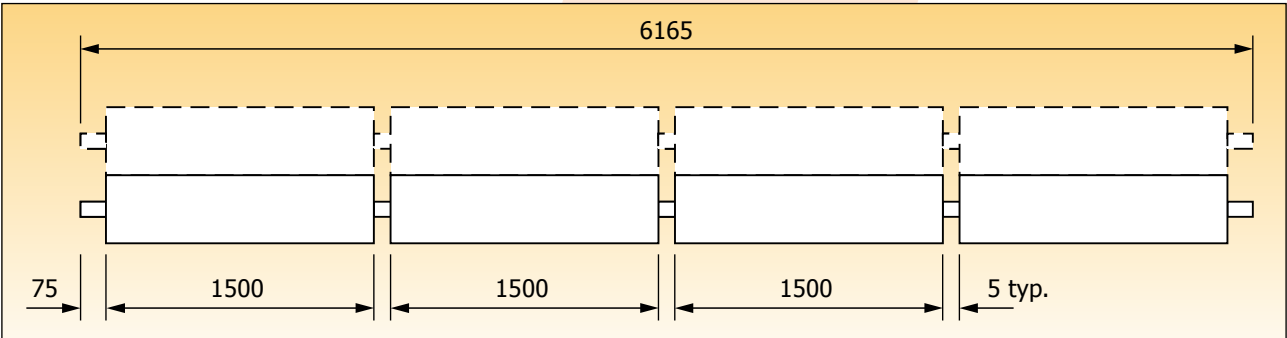

M1 and M2 strip - nominal length 6.0m

Dimensions (flanged)

DETAIL 'A' - SINGLE HEADED PANEL

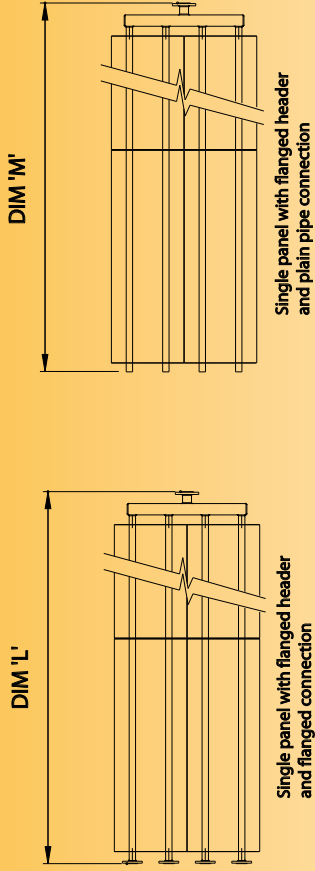

NOMINAL LENGTH	DIM 'M'	
	FLANGED	UNFLANGED
1.5m	1,813mm	1,808mm
3.0m	3,318mm	3,313mm
4.5m	4,823mm	4,818mm
6.0m	6,328mm	6,323mm

DETAIL 'B' - DOUBLE HEADED PANEL

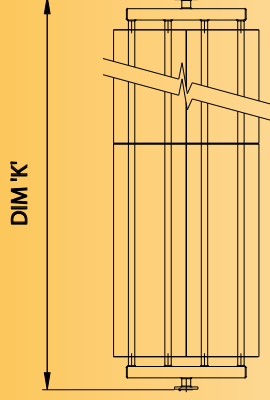

NOMINAL LENGTH	DIM 'K'
1.5m	1,966mm
3.0m	3,471mm
4.5m	4,976mm
6.0m	6,481mm

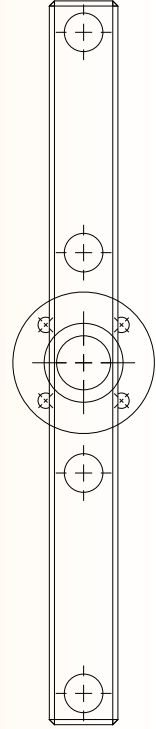
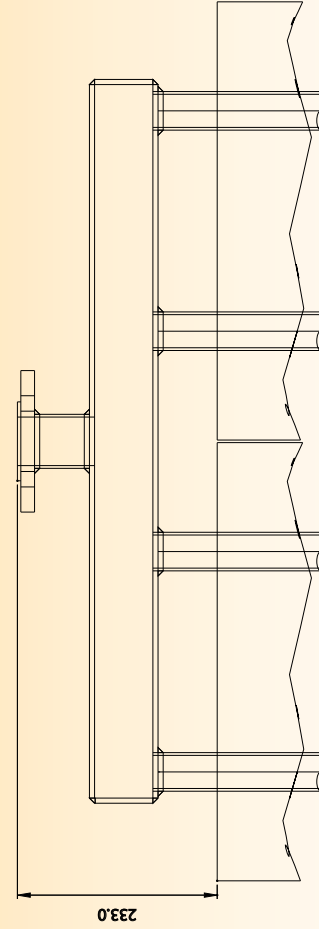
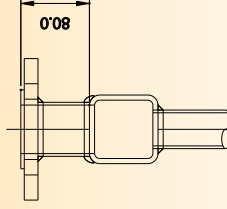

- NOTES:-**
1. HEADER FINISHED MATT BLACK, UNLESS SPECIFIED ON WORKS ORDER BREAKDOWN
 2. PRESSURE RATING AS PER STANDARD SPECIFICATION
 3. HEADER FLANGES TO BE DN50 PN40 TO BS EN 1092 (GASKETS & FITTINGS BY OTHERS)



Engineering Specification

Dunham Strip shall be manufactured by Dunham-Bush Ltd, Downley Road, Havant, Hants, PO9 2JD.

The quantities and sizes shall be as indicated in the selection schedule and/or on the drawings. The construction of all radiant panels must comply with the following specification:-

General Assembly

Each Dunham Strip shall be assembled from 1500mm long aluminium radiating plates and BS EN 10 255 DN32 (1 1/4") steel pipe. The pipe shall be securely clamped to the radiating plate by means of 3mm thick steel clamps, fixed at approximately 380mm centres with threaded fasteners, to ensure good contact and heat transfer.

Each radiating plate shall be anchored to the tube at one end to prevent displacement from differential expansion. Longer lengths of Dunham Strip shall comprise two, three and four radiating plates to form 3.0m, 4.5m and 6.0m long panels respectively. A clearance of 5mm shall be maintained between radiating plates to allow for differential expansion.

Insulation

Insulation shall be fitted to the upper side of the radiant panel and held in place with insulation cover plates. Insulation shall be 25mm thick fibre-glass, foil-backed on one side.

Radiating Plates

Radiating plates shall be manufactured from 1.5mm aluminium sheet, formed to accept DN32 steel pipe, retain insulation and be self-supporting and rigid.

Steel Pipe

Steel pipe shall be BS EN 10 255 DN32mm (1 1/4") medium series steel pipe. When specified, heavy series pipe shall be fitted.

Connections

Connections shall be plain ended for welding; screwed DN32 male taper to BS EN 10 266; flanged DN32 PN40; grooved for suitable fittings such as 'victaulic' or 'gruvlock'; box headers with DN50 PN40 flanges. All flanges to BS EN 1092.

Performance

Dunham Strip shall be independently tested and rated in accordance with BS EN 442 : Part 2.

Accessories

Dunham Strip shall be supplied with the following accessories, if specified :-

Sliding brackets
SB1, SB2, SB3 or SB4

End closers
EC1 or EC2

Cover plates
CP1 or CP2

Finish

Radiating plates, steel pipe ends, flanged headers and accessories shall be finished in matt black polyester powder BS 00 E 53 - 10% gloss.

Site Working And Test Pressures

Dunham Strip shall be suitable for the following maximum site test pressures.

Pipe type	Cold test pressure (bar g)	Max. working pressure (bar g)
Plain ends	25	17
Screwed ends	21	14
Flanged ends	25	17
Box Headers	25	17
Victaulic	refer to fitting manufacturer's recommendations	

Construction

Handling

The purchaser is responsible for off-loading. 1.5m, 3.0m radiant panels can usually be lifted by two persons, but longer panels may require a third person providing support in the middle. When a significant quantity of radiant panels is delivered, they may be palletised and shrink-wrapped, so fork lift truck or similar form of lifting equipment is required. Care should be taken to ensure panels are not dropped or suffer impact in any circumstances.

Storage

Radiant panels should be stored under clean, dry indoor conditions. Any packaging should not be removed until panels are ready for installation, unless damage in transit is suspected. Note - the purchaser must examine the panels promptly upon receipt and any claims for damage will only be accepted if, at the time of delivery, the delivery note is endorsed with a note detailing the damage and countersigned by the transport company. Each panel may be marked with a stencil reference if specified on the order.

Preparation

Extensive modification to the building fabric should not normally be necessary. However, proper provision for fixings must be arranged. The structure to which the panels are to be fixed must be fit for purpose and be capable accepting drop rods or similar suspension fixings.

Installation

Radiant panels are supplied with Sitework Instructions, which provide full details on installing, connecting and commissioning radiant panels. Additional copies are available upon request.

Grade each run by means of adjustable drop rods. Hot water installations are usually graded to a minimum 1:250 in the direction of flow, to the highest point of the return main, which should have an air vent. Steam installations must be graded to a minimum 1:200 in the direction of flow, down to a suitable steam trap.

Pipework Connections

Connections will be as specified, from a choice of plain tube ends for welding, screwed ends, flanged ends or grooved.

The position of flow and return connections will depend upon the circuitry of the installation; refer to the mechanical services drawing.

Tubes should be connected in parallel to minimise bowing due to differential expansion. If end connections and return headers are given sufficient flexibility, then expansion loops should not be necessary.



Prices and Conditions of Sale

Prices

Dunham-Bush do not issue price lists, but will be pleased to provide a written quotation upon request. All quotations are normally prepared by a member of our national network of sales agents and representatives. For further details, please contact Dunham-Bush head office in Havant, Hants.

Conditions of sale

Standard conditions of sale are included on the reverse of all order acknowledgements. Further copies are available upon request.





Supply

Availability

Dunham Strip radiant panels are supplied direct from the Dunham-Bush factory in Havant. All panels are made to order, and availability can vary with demand and should therefore be checked at the time of ordering. Contact a Dunham-Bush sales agent/representative for typical lead times.

Packaging

Dunham Strip panels are packed for storage in dry, indoor conditions. If specified, each panel will be marked with its own unique stencil reference for on-site identification.

Ordering

To ensure the rapid processing of your order, please refer to the relevant quotation and appropriate correspondence. Please send your order directly to the Dunham-Bush sales agent/representative who provided the quotation. Use the product description code below to specify a Dunham Strip panel.

Code posn	1	2	3
Code posn	Code	Description	
1	M1	1 pipe Dunham-Strip	
	M2	2 pipe Dunham-Strip	
	M3	3 pipe Dunham-Strip	
	M4	4 pipe Dunham-Strip	
2	15	Nominal length 1.5m	
	30	Nominal length 3.0m	
	45	Nominal length 4.5m	
	60	Nominal length 6.0m	
3	MP	Medium series DN32 (1¼") pipe - plain ends	
	MS	Medium series DN32 (1¼") pipe - screwed ends	
	MF	Medium series DN32 (1¼") pipe - flanged ends - PN40 BS 4504	
	MG	Medium series DN32 (1¼") pipe - Grooved	
	HP	Heavy series DN32 (1¼") pipe - plain ends	
	HS	Heavy series DN32 (1¼") pipe - screwed ends	
	HF	Heavy series DN32 (1¼") pipe - flanged ends - PN40 BS 4504	
	HG	Heavy series DN32 (1¼") pipe - Grooved	

Table 6: Product description code for Dunham-Strip - use this code when specifying an individual radiant panel

Code	Description
SB1	Sliding bracket for M1 Duham-Strip
SB2	Sliding bracket for M2 Duham-Strip
SB3	Sliding bracket for M3 Duham-Strip
SB4	Sliding bracket for M4 Duham-Strip
CP1	Cover plate kit for M1 Dunham-Strip
CP2	Cover plate kit for M2 Dunham-Strip
EC1	End colsure kit for M1 Dunham-Strip
EC2	End colsure kit for M2 Dunham-Strip
HD2	Box Header for M2 Dunham-Strip
HD3	Box Header for M3 Dunham-Strip
HD4	Box Header for M4 Dunham-Strip

Table 7: Optional accessories for Dunham Strip

Note: Sliding brackets SB1, SB2, SB3 and SB4 - Use 1 no. @ 3m intervals along the Dunham Strip run
 Use 1 no. CP1 and 1 no. CP2 for M3 Dunham Strip
 Use 2 no. CP2 for M4 Dunham Strip
 Use 1 no. EC1 and 1 no. EC2 for M3 Dunham Strip
 Use 2 no. EC2 for M4 Dunham Strip
 All kits include appropriate fixings
 CP1 & 2 not suitable for Flanged connections



Dunham-Bush operates a quality control system and is a company of assessed capability to BS EN ISO 9001 : 2000

Whatever the product, wherever its eventual destination, the Dunham-Bush design and manufacturing policy has always been firmly based on technical quality.

Product support

In the United Kingdom and Ireland, Dunham-Bush have a network of sales agents and representatives, situated at strategic locations, to provide local support in pricing and selection. Further technical and application support is available at Dunham-Bush head office and factory in Havant.

Other Dunham-Bush products

Series AM fan convector
'Avant-Garde' fan convectors
Series BM fan convector
Series CM fan convector

Series F fan coil units
Panther fan coil units
Cougar fan coil units
Lepoard fan coil units
Lynx fan coil units
Puma fan coil units
Jaguar fan coil units

DBB Air handling units
DBM Air handling units
DBH & DBH_p Air handling units

Packaged chillers

Evolution radiant panels
Evo-Lite radiant panels

Finvector perimeter heating system
Hydrocourse trench heating
Series UH unit heaters
WarmSAFE LST radiators
Sentry door curtains



Manufacturer reserves the right to change any product specification without notice.

DUNHAM-BUSH Ltd.
Downley Road, Havant
Hampshire PO9 2JD
Tel: 023 9247 7700
Fax: 023 9245 0396
email: info@dunham-bush.co.uk
www.dunham-bush.co.uk

PDS-1000-H-0126-05
MAR 2006